

SPECIAL RETAINERS ON DEMAND.

HP ACCU-LOCK® RETAINER INSERTS



Do-It-Yourself.

Create, modify and reuse special retainers on-site and on demand with HP Accu-Lock® Retainer Inserts by Wilson Tool. HP Accu-Lock simplifies the use of special retainers by eliminating the need for complicated jigs, inspection fixtures and specialized knowledge to machine ball holes into the punch plate. In fact, HP Accu-Lock eliminates the ball hole. Punches are held securely in place with a straight-line machined hole that can easily be created in-house.



Shorter Lead Times and Less Waste Means Lower Costs.

Purchasing custom retainers for a special request is costly and can add weeks to a job. With HP Accu-Lock, you can not only create your own special retainers in-house but also modify and reuse existing retainers. Cut your lead times from several weeks to a day and significantly reduce waste.

HP Accu-Lock Retainer Inserts let you:

- Create new special retainers in-house
- Modify and reuse existing retainers
- Hold punches securely and accurately



HP Accu-Lock Retainer Inserts are fully compatible with all ball lock punches, including HP Ball Lock punches from Impax Tooling Solutions.

Available in Metric and Imperial sizes.

Call 1.800.944.4671 or visit www.wilsontool.com today for more information.



Strength. Performance. Innovation.



HP ACCU-LOCK RETAINER INSERTS

TECHNICAL SPECIFICATIONS

HP Accu-Lock Retainer Inserts are available for all heavy duty and light duty applications.

	PUNCH HOLE Ø	INSERT	CENTER TO CENTER	INSERT HOLE Ø	HEAD C-BORE Ø	PLATE THICKNESS
Heavy Duty	"A"	PART #	"B"	"C"	"D"	"E"
	.375	IHIS037	.375	.6255	.750	1.38
	.500	IHIS050	.480	.8130	1.00	1.38
	.625	IHIS062	.543	.8130	1.00	1.38
	.750	IHIS075	.605	.8130	1.00	1.38
	.875	IHIS087	.668	.8130	1.00	1.38
	1.00	IHIS100	.730	.8130	1.00	1.38
*1.25	IHIS125	.855	.8130	1.00	1.38	
Light Duty	.250	ILIS025	.280	.5005	.625	1.00
	.375	ILIS037	.325	.5005	.625	1.00
	.500	ILIS050	.406	.5630	.720	1.00
	.625	ILIS062	.469	.5630	.720	1.00
	.750	ILIS075	.563	.6255	.750	1.00
	.875	ILIS087	.625	.6255	.750	1.00
	1.00	ILIS100	.688	.6255	.750	1.00

*Tolerance for Ø1.250 punch; hole is $+.0006/+.0003$

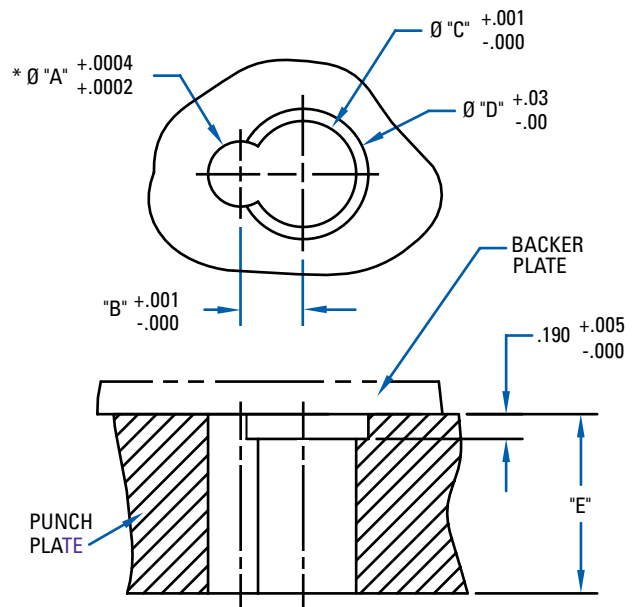

	PUNCH Ø	INSERT	INSERT Ø	HEAD Ø	LENGTH
Heavy Duty	"P"	PART #	"D"	"H"	"L"
	.375	IHIS037	.6250	.735	1.38
	.500	IHIS050	.8125	.980	1.38
	.625	IHIS062	.8125	.980	1.38
	.750	IHIS075	.8125	.980	1.38
	.875	IHIS087	.8125	.980	1.38
	1.00	IHIS100	.8125	.980	1.38
1.25	IHIS125	.8125	.980	1.38	
Light Duty	.250	ILIS025	.5000	.615	1.00
	.375	ILIS037	.5000	.615	1.00
	.500	ILIS050	.5625	.690	1.00
	.625	ILIS062	.5625	.690	1.00
	.750	ILIS075	.6250	.735	1.00
	.875	ILIS087	.6250	.735	1.00
	1.00	ILIS100	.6250	.735	1.00

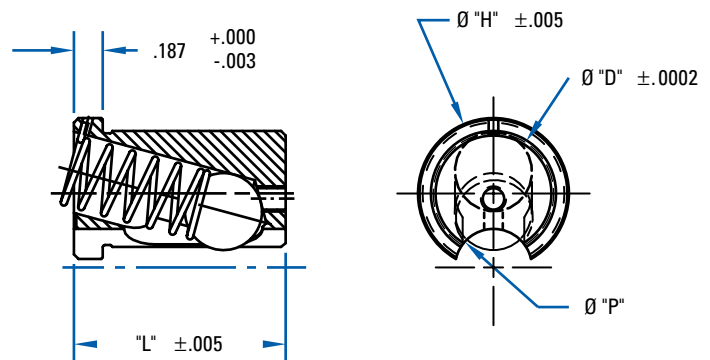

Tel: 800-944-4671 • Fax: 800-944-4679
www.wilsontool.com



Strength. Performance. Innovation.