

SPECIAL RETAINERS ON DEMAND.

METRIC HP ACCU-LOCK® SPECIAL RETAINER INSERTS



Do-It-Yourself.

Create, modify and reuse special retainers on-site and on demand with HP Accu-Lock® Retainer Inserts by Wilson Tool. HP Accu-Lock simplifies the use of special retainers by eliminating the need for complicated jigs, inspection fixtures and specialized knowledge to machine ball holes into the punch plate. In fact, HP Accu-Lock eliminates the ball hole. Punches are held securely in place with a straight-line machined hole that can easily be created in-house.



Shorter Lead Times and Less Waste Means Lower Costs.

Purchasing custom retainers for a special request is costly and can add weeks to a job. With HP Accu-Lock, you can not only create your own special retainers in-house but also modify and reuse existing retainers. Cut your lead times from several weeks to a day and significantly reduce waste.

HP Accu-Lock Retainer Inserts let you:

- Create new special retainers in-house
- Modify and reuse existing retainers
- Hold punches securely and accurately



HP Accu-Lock Retainer Inserts are fully compatible with all ball lock punches, including HP Ball Lock punches from Impax Tooling Solutions.

Available in Metric and Imperial sizes.

Call 1.800.944.4671 or visit www.wilsontool.com today for more information.



Strength. Performance. Innovation.



HP ACCU-LOCK RETAINER INSERTS

TECHNICAL SPECIFICATIONS

HP Accu-Lock Retainer Inserts are available for all heavy duty and light duty applications.

	PUNCH HOLE Ø	INSERT	CENTER TO CENTER	INSERT HOLE Ø	HEAD C-BORE Ø	PLATE THICKNESS
Heavy Duty	"A"	PART #	"B"	"C"	"D"	"E"
	10mm	MHIS010	10.0	16.013	20.0	34.7
	13mm	MHIS013	11.5	20.013	25.0	34.7
	16mm	MHIS016	13.0	20.013	25.0	34.7
	20mm	MHIS020	15.0	20.013	25.0	34.7
	25mm	MHIS025	17.5	20.013	25.0	34.7
	*32mm	MHIS032	21.0	20.013	25.0	34.7
*40mm	MHIS040	25.0	20.013	25.0	34.7	
Light Duty	6mm	MLIS006	6.5	12.013	15.0	25.7
	10mm	MLIS010	9.0	14.013	17.0	25.7
	13mm	MLIS013	10.5	14.013	17.0	25.7
	16mm	MLIS016	12.0	14.013	17.0	25.7
	20mm	MLIS020	14.0	16.013	19.0	25.7
	25mm	MLIS025	16.5	16.013	19.0	25.7
	*32mm	MLIS032	20.0	16.013	19.0	25.7
*38mm	MLIS038	23.0	16.013	19.0	25.7	

*Tolerance for Ø1.250 punch; hole is +.0006/+0.003

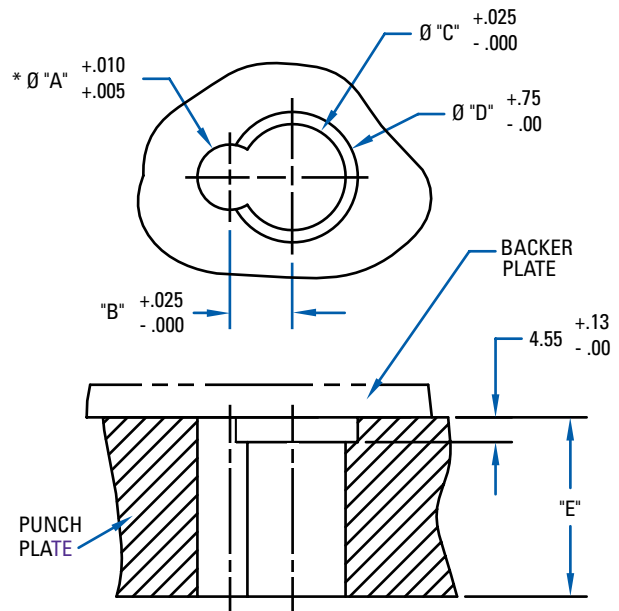

	PUNCH Ø	INSERT	INSERT Ø	HEAD Ø	LENGTH
Heavy Duty	"P"	PART #	"D"	"H"	"L"
	10mm	MHIS010	16	19.6	34.7
	13mm	MHIS013	20	24.6	34.7
	16mm	MHIS016	20	24.6	34.7
	20mm	MHIS020	20	24.6	34.7
	25mm	MHIS025	20	24.6	34.7
	32mm	MHIS032	20	24.6	34.7
40mm	MHIS040	20	24.6	34.7	
Light Duty	6mm	MLIS006	12	14.6	25.7
	10mm	MLIS010	14	16.6	25.7
	13mm	MLIS013	14	16.6	25.7
	16mm	MLIS016	14	16.6	25.7
	20mm	MLIS020	16	18.6	25.7
	25mm	MLIS025	16	18.6	25.7
	32mm	MLIS032	16	18.6	25.7
38mm	MLIS038	16	18.6	25.7	

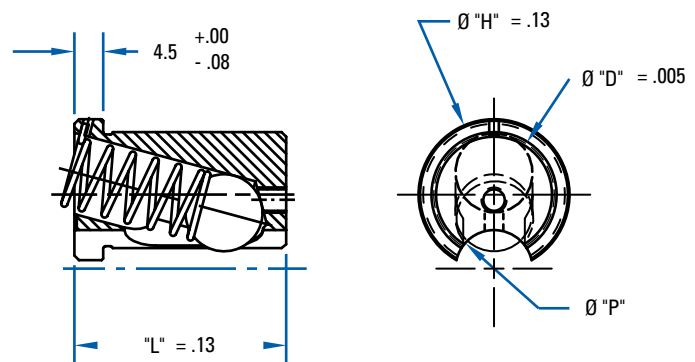

Tel: 800-944-4671 • Fax: 800-944-4679
www.wilsontool.com



Strength. Performance. Innovation.