

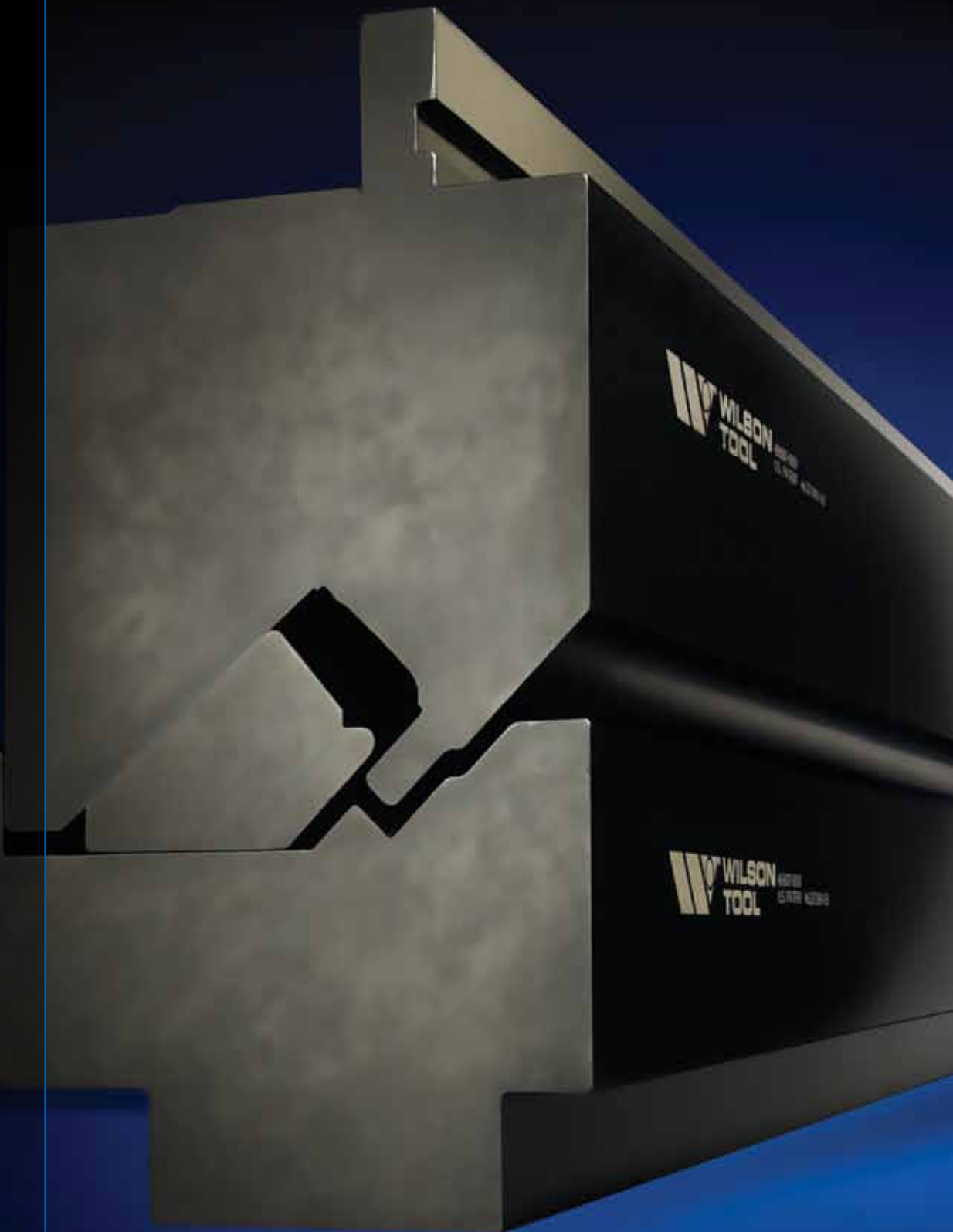

## **PRESS BRAKE SPECIALS**

**Innovative  
Solutions for  
Challenging  
Applications.**



*Strength. Performance. Innovation.*

# CUSTOM PRESS BRAKE TOOLING FOR YOUR MOST CHALLENGING APPLICATION.

***No matter how unique your tooling needs, Wilson Tool has the ingenuity and the experience to design and manufacture press brake special tooling that will improve your bending performance.***

## **Innovative Engineering**

Over the years we've helped customers solve their most challenging bending and forming applications with innovative tooling solutions for the press brake that simplify complex bends and improve productivity. The many examples of press brake specials tooling in this catalog are a small sampling of some of the unique solutions we've created for customers like you.

## **Challenge Us.**

If you don't see a suitable special tooling on these pages, don't worry. We like the tough stuff. If you need it done better or faster, Wilson Tool is up to the challenge. Bring us your parts, prints, designs, CAD files, napkin drawings – whatever you have – and our industry-leading experts will work with you to create the ideal tooling solution.

## **Quality Materials. Quality Control.**

Like all Wilson Tool products, our special tooling is produced from high quality proprietary grade tool steels that feature custom elements designed to enhance tool life and performance. We thoroughly inspect each special tool we produce and include a sample that was produced during this testing process with each special tool that is shipped. When testing is complete and the customer is satisfied, we store our data and specifications for each special tool in our computer system for safe, confidential storage and easy retrieval at a later date.

## **Quick Quotes. Short Lead Times.**

Wilson Tool is committed to providing better solutions, faster. We'll respond to your special tooling request with a quote in 24 hours. And we offer the fastest lead times on special tooling in the industry.

## **Precision Ground to Reduce Waste.**

Wilson press brake tooling is precision ground to a tolerance of +/- .0008" (.02mm) on all critical dimensions for increased reliability. Common centerlines on all punches eliminate costly time spent locating the back gauge origin position and subsequent scrap.



### Nitrex™ Extends Tool Life.

Wilson Tool's exclusive Nitrex high endurance surface enhancement increases press brake tooling life by several times that of ordinary tooling. Wilson's patented process provides a surface hardness of HRC-70, increasing long-term durability and minimizing galling in even the toughest bending applications.

Nitrex also adds lubricity to press brake tooling that lowers friction, effectively minimizing galling. Unlike ordinary press brake tooling Nitrex treated tools experience zero corrosion, resulting in faster cleanups and longer lasting tooling.

### Laser Hardening Optional.

Wilson Tool now offers optional laser hardening to further improve heat and wear resistance of press brake tooling. Laser hardening is ideal for high wear applications.

## TABLE OF CONTENTS

- Specials Checklist . . . . . 3
- General Applications. . . . . 4
- Forming . . . . . 11
- Stamping . . . . . 13
- Mechanical Applications . . . . . 15
- Special Shape Punches. . . . . 19
- Holdings . . . . . 20
- Wiping and Rotary Bending. . . 21
- General Applications. . . . . 23

## TIP MODIFICATIONS

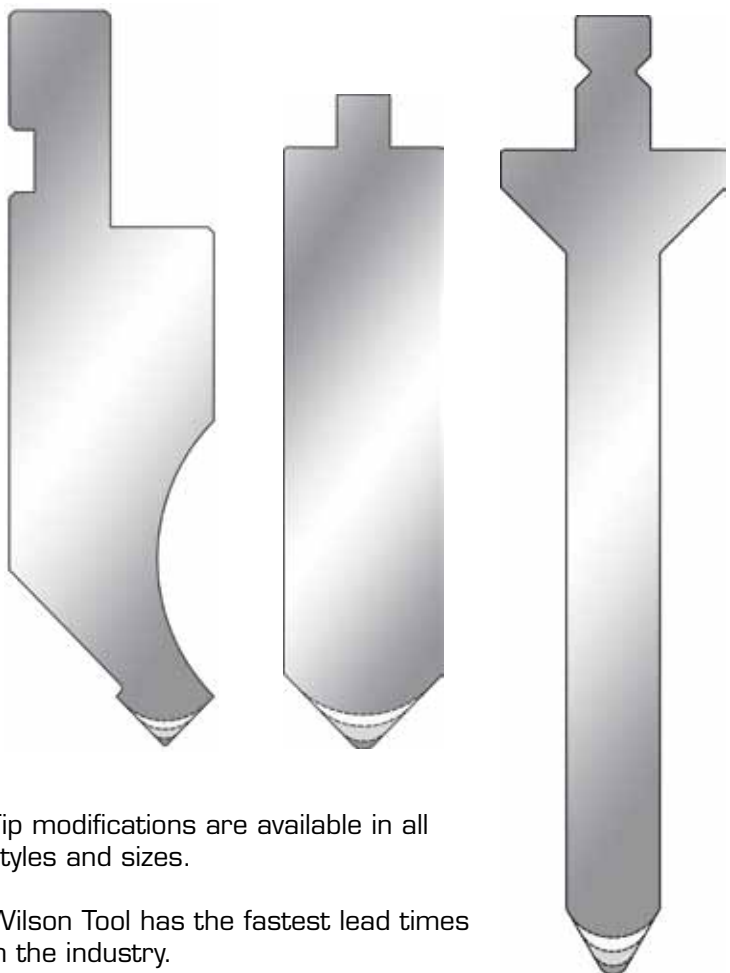

Tip modifications are available in all styles and sizes.

Wilson Tool has the fastest lead times in the industry.



# SPECIALS CHECKLIST

**COMPANY:** \_\_\_\_\_  
**CONTACT:** \_\_\_\_\_  
**PHONE:** \_\_\_\_\_ **SALES ENGINEER:** \_\_\_\_\_  
**QUOTE #:** \_\_\_\_\_ **SALES DESK CONTACT:** \_\_\_\_\_

## MACHINE SPECIFICATIONS:

Brake Make / Model: \_\_\_\_\_  
 Open Height: \_\_\_\_\_  
 Tonnage: \_\_\_\_\_

## TOOLING AND APPLICATION

Tooling Type:  American  European  WT  Other \_\_\_\_\_

Length of Bend: \_\_\_\_\_

Material Type: \_\_\_\_\_ Thickness: \_\_\_\_\_

Is customer currently performing this bend?  Yes  No

If yes, W.T. Repeat Replicate Customer Tool Redesign

Explain: \_\_\_\_\_  
 \_\_\_\_\_

## TOLERANCE BLOCK

Part Radii Tolerance: \_\_\_\_\_  
 (Tolerances tighter than +/- 5% may affect price / lead time)

Part Bend Angle Tolerance: \_\_\_\_\_  
 (Tolerances tighter than +/- 2% may affect price / lead time)

Estimated Annual Usage: \_\_\_\_\_



**Local**  
 Tel: 651-286-6001  
 Fax: 651-286-5959

**Toll Free U.S.A. & Canada**  
 Tel: 800-445-4518  
 Fax: 800-539-4590

**Toll Free Mexico**  
 Tel: 001-800-741-2510  
 Fax: 001-800-544-2096

**Website & Email**  
 www.wilsontool.com  
 pressbrake@wilsontool.com

## CUSTOM HEMMING

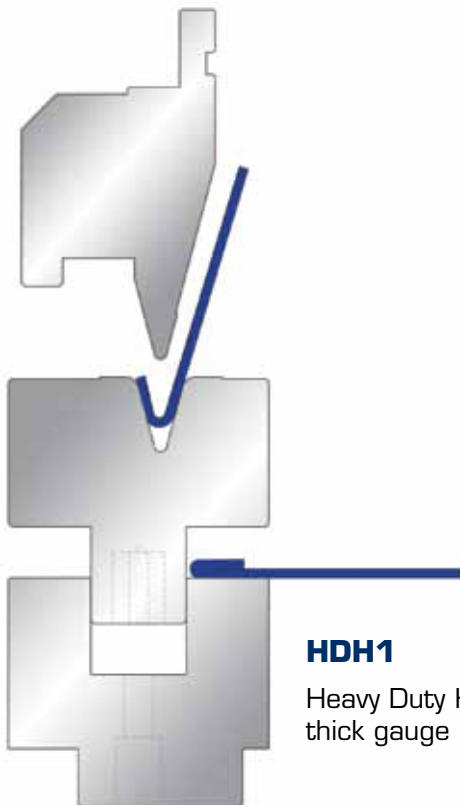
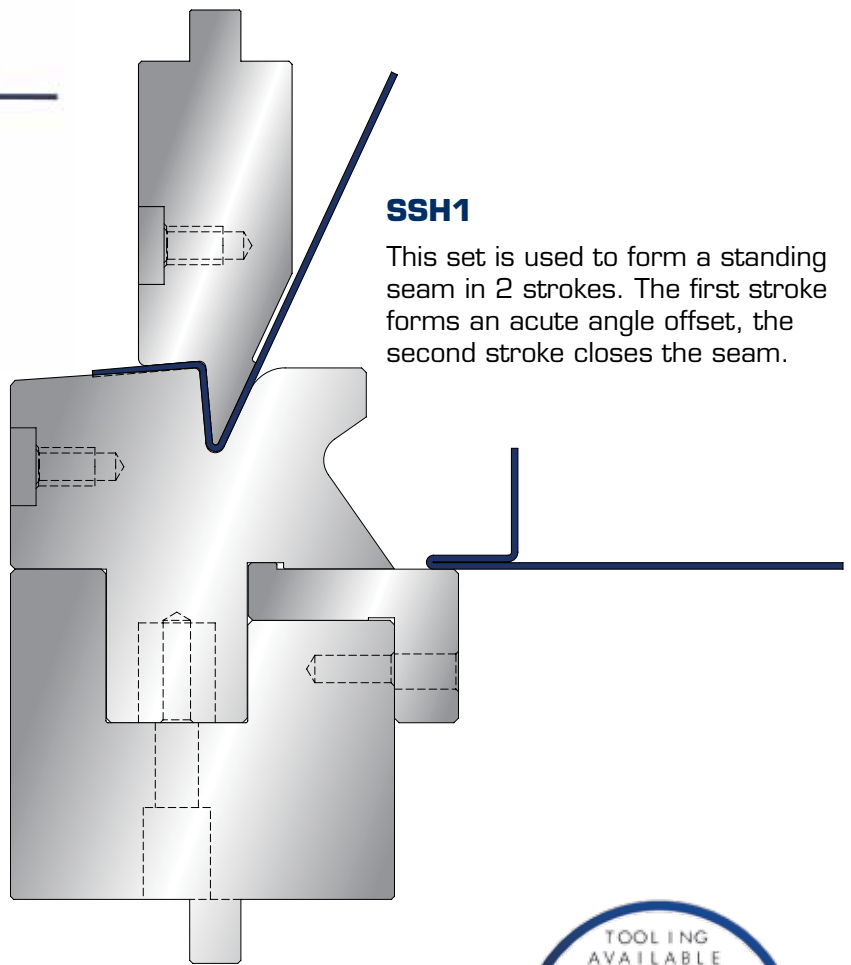
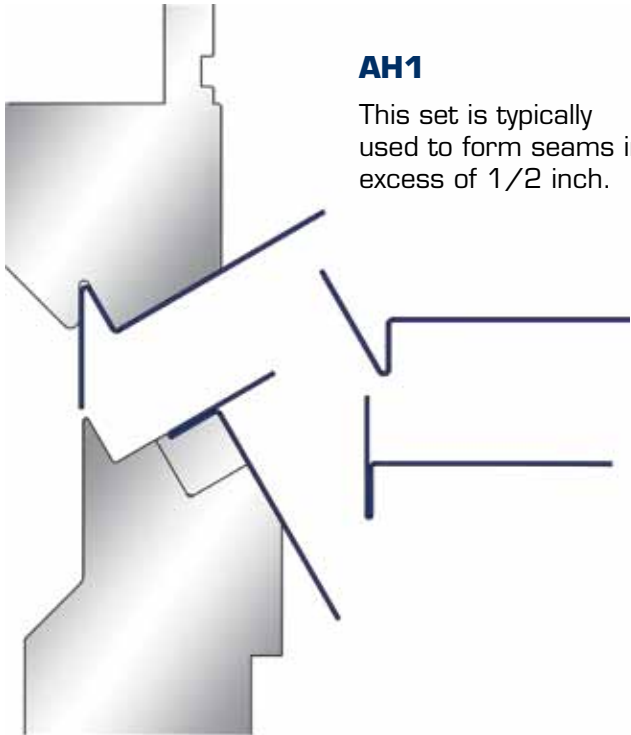

## CUSTOM HEMMING

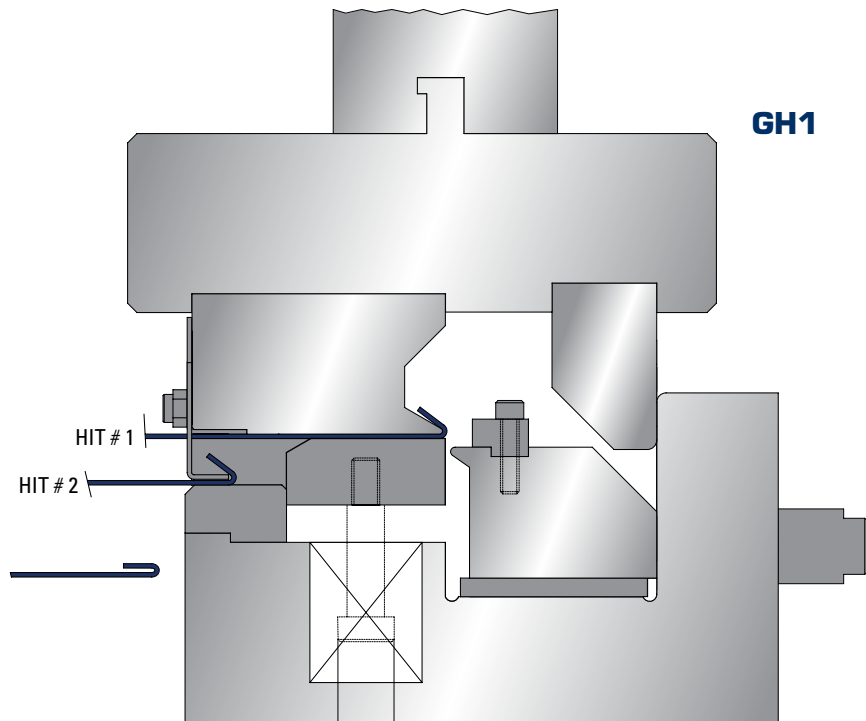
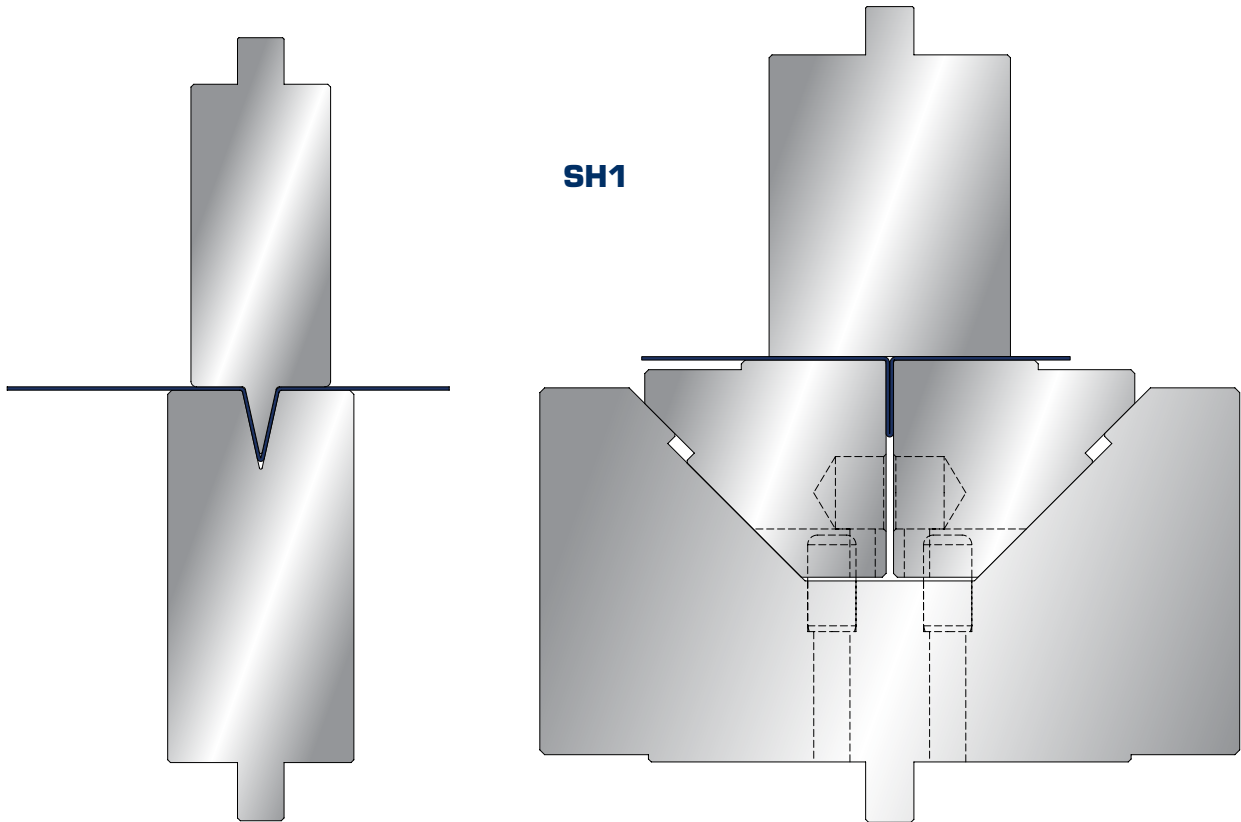

## CUSTOM HEMMING

SSH2

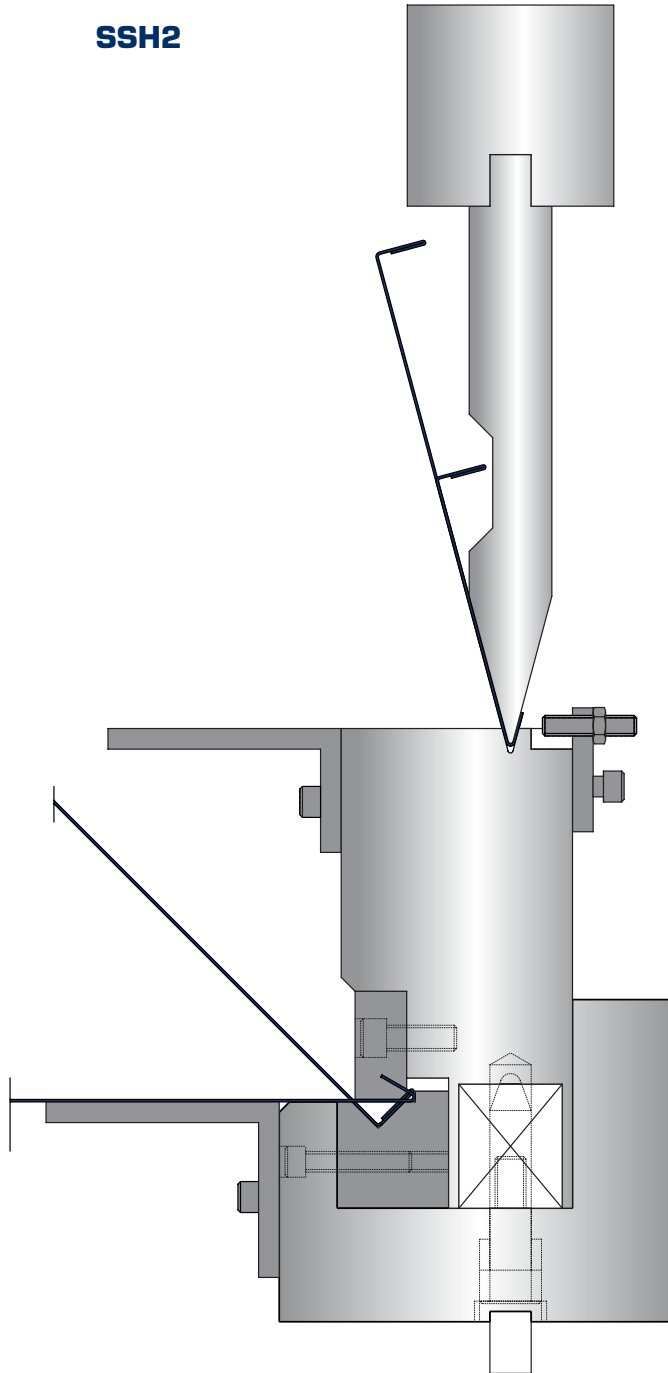

## OFFSET

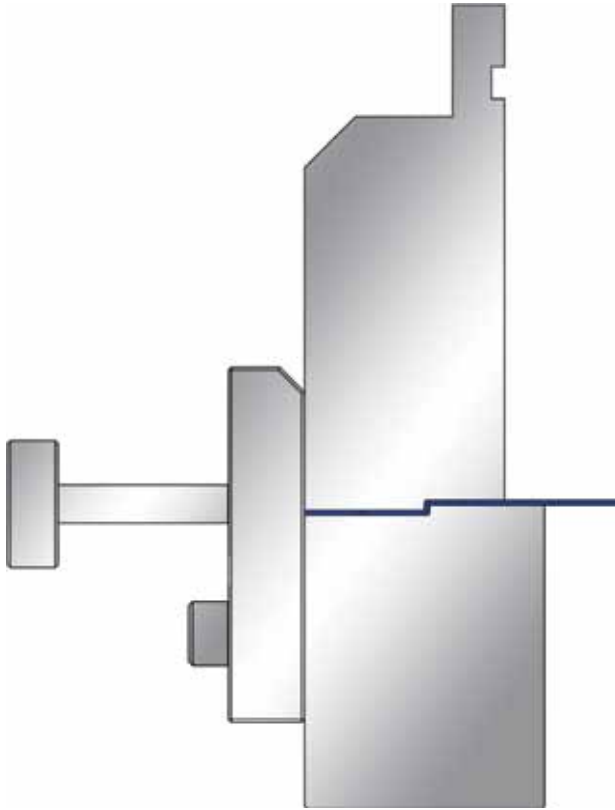

### H Offset

#### H01

This set is used when forming offsets that are approximately one material thickness. Prevents material whip up. Thrust plates and adjustable back gauging are provided.

#### A01

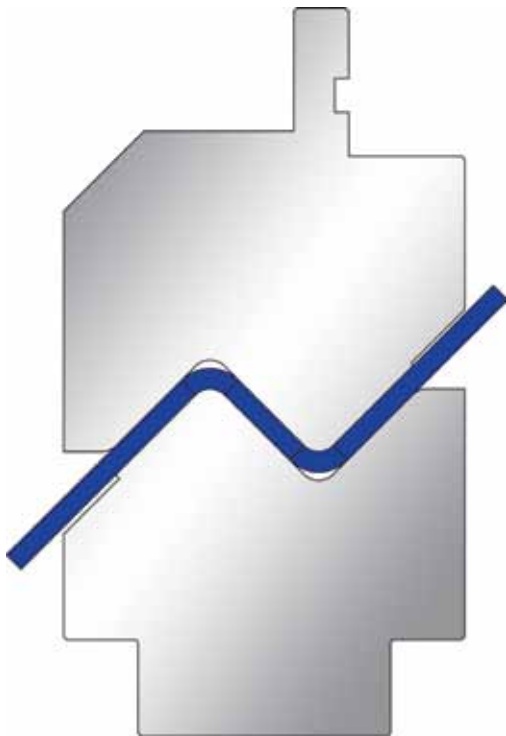
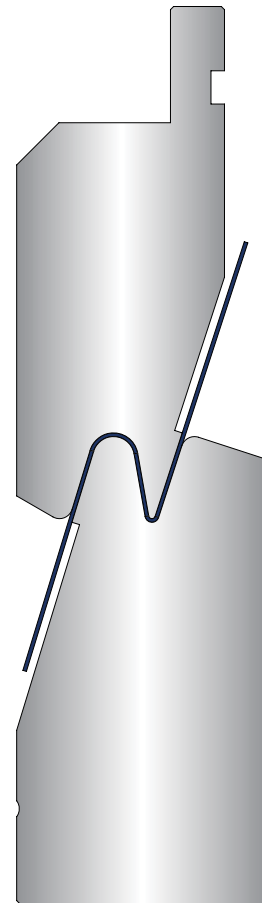

### Large Offset

#### L01

This set is used for heavy gauge, large offset bending.



## DIES

### ROLLING SHOULDER DIE

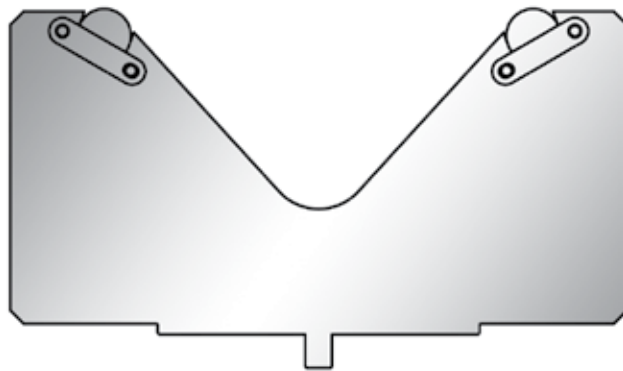

8" V

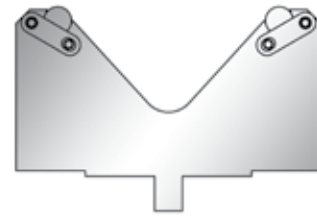

4" V

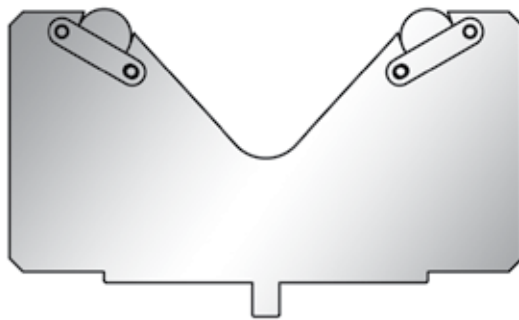

6" V



2" V

Insertable shoulder dies are ideal for extreme wear conditions created then forming heavy plate and abrasive materials.

Replaceable inserts eliminate the need for replacing the entire die when the die shoulders wear.

Available in multiple V sizes and 75° and 85° configurations.

### ADJUSTABLE DIE

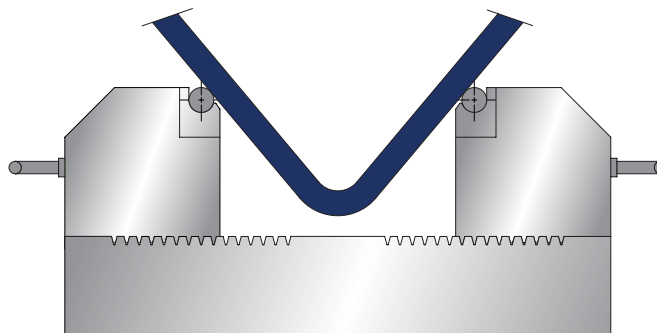

## LARGE RADII

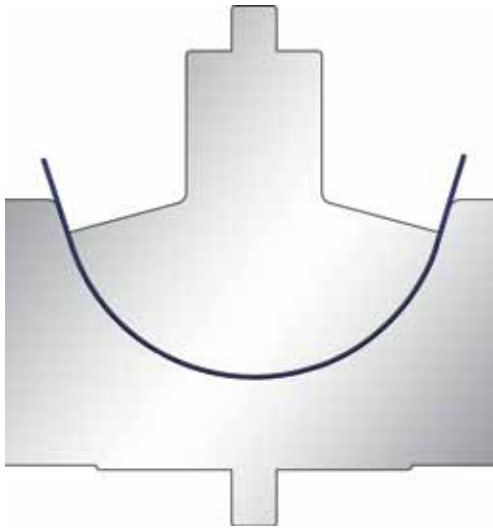

### LR1

This is a bottoming radius set with spring-back allowance built in. It is manufactured to form a radius in a specific type and thickness of material for tight tolerance requirements.

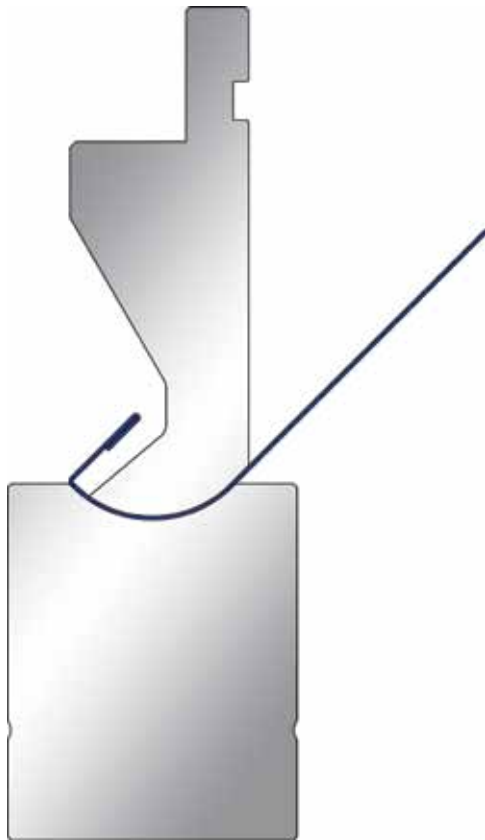

### LR2 Multi Hit Rad

This set is used when a full radius is required before the flange. May require multiple strokes.

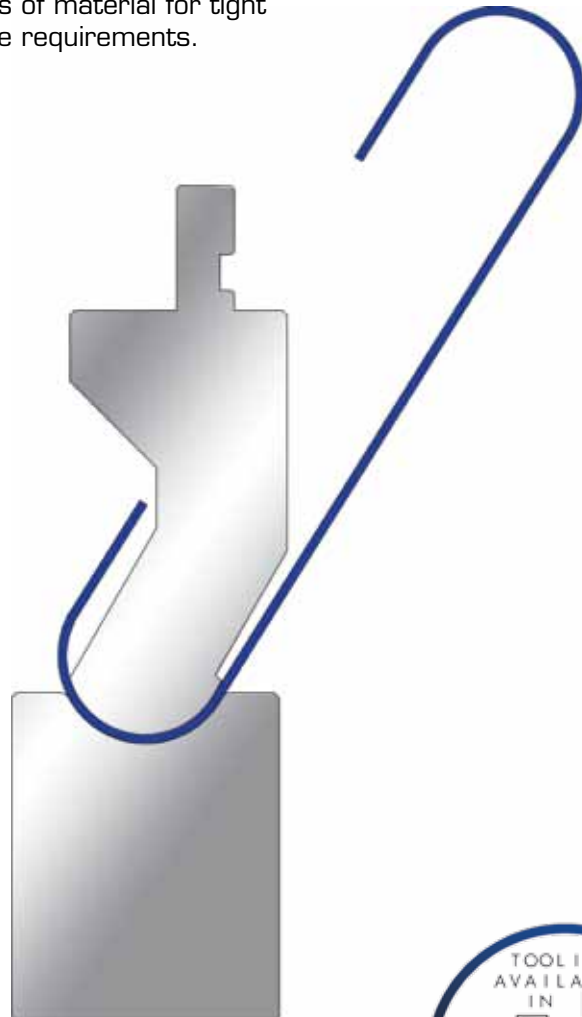

### LR3 Multi Hit Rad

This set is used when the return flange starts at the radius end. May require multiple strokes.



## V-RIB / STRENGTHENING RIB

### VR1

These sets produce a v-rib in one stroke. Spring back allowance is built in.

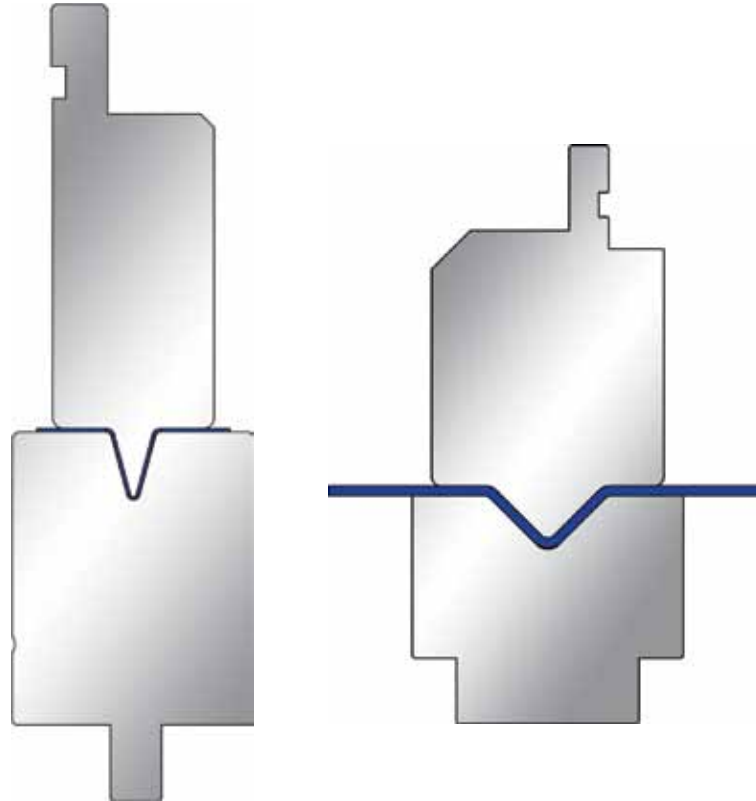

### SR1

These sets produce a strengthening rib in one stroke. Spring back allowance is built in. Closed end and open end ribs are available.

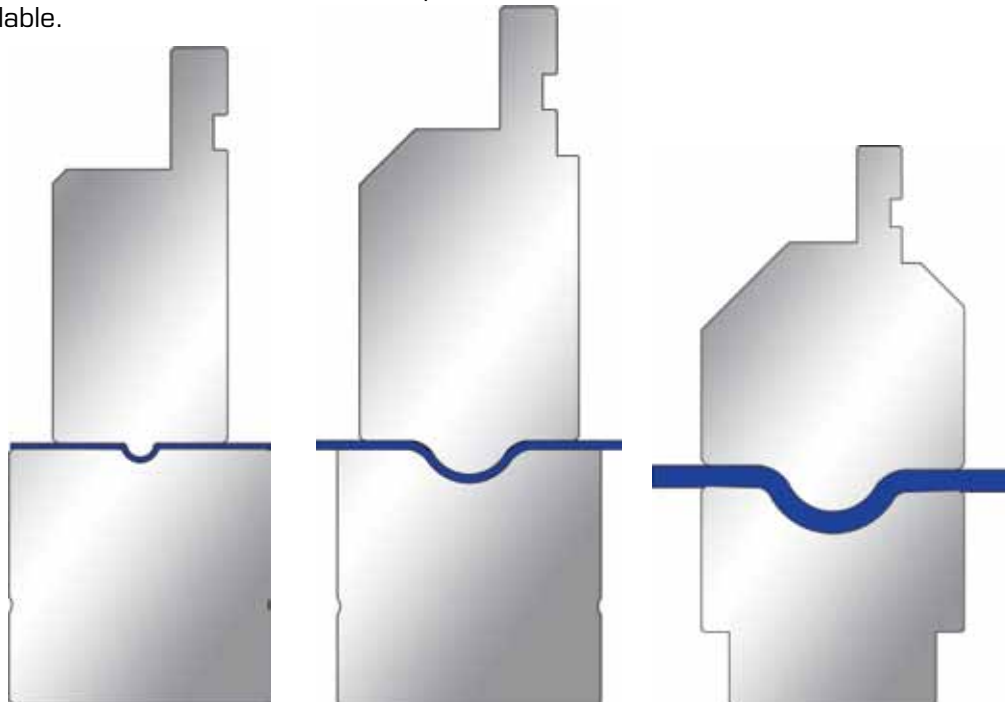

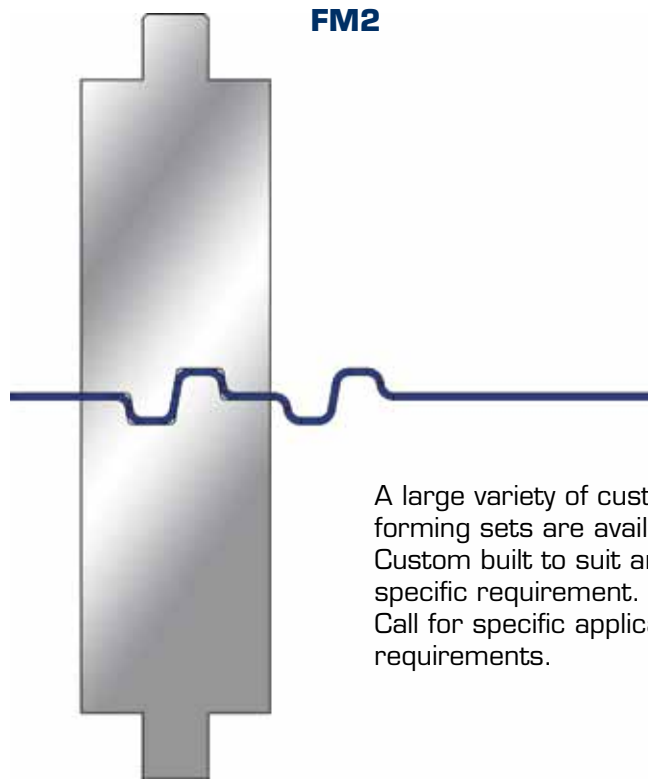
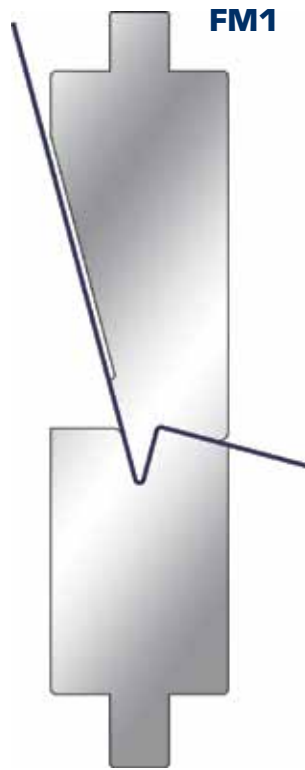
**FORMING**

A large variety of custom forming sets are available. Custom built to suit any specific requirement. Call for specific application requirements.

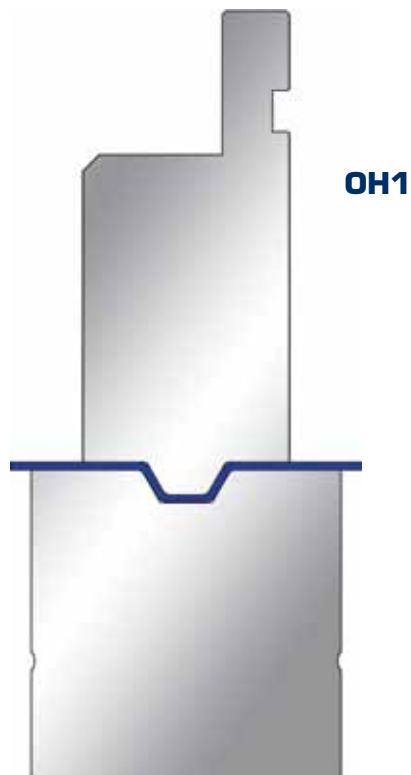
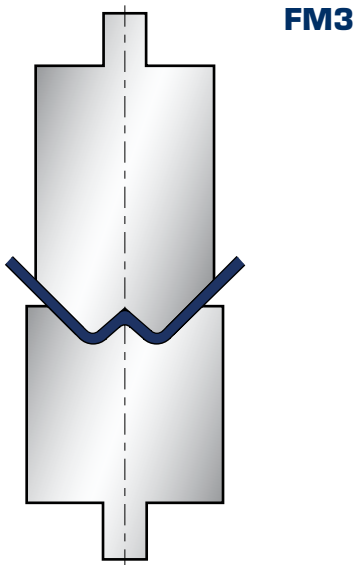

## ROD BENDING

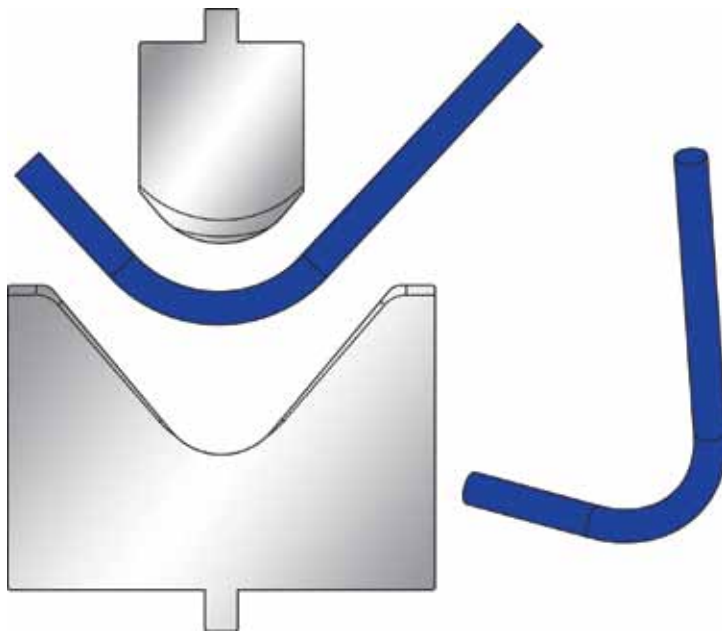

### RB1

These sets provide nesting for the rod during the forming process.

## WINDOW

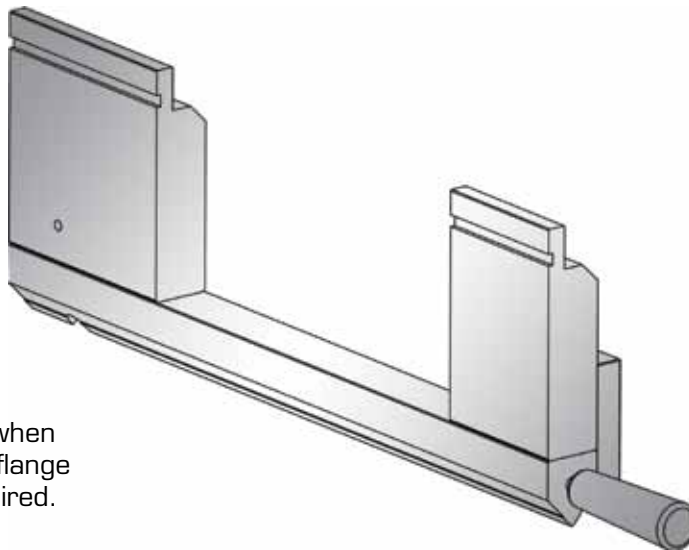

### W1

This set is used when minimum return flange clearance is required.

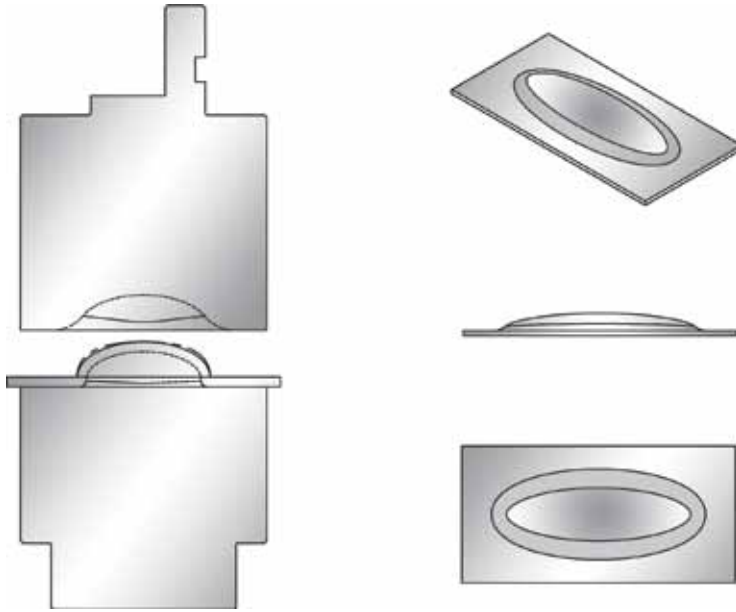

**EMBOSS & LOGO****EM1**

A variety of raised emboss and chisel point emboss sets are available.

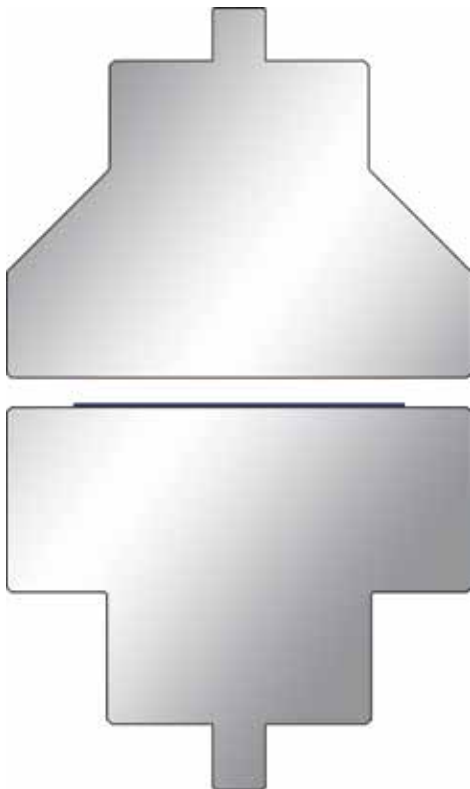
**LG1**

## LETTERSTAMP AND LOUVER

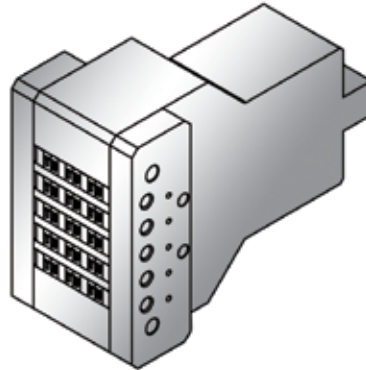
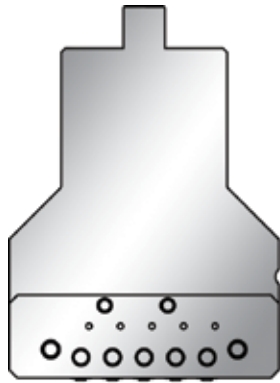

### LS1

This set provides chisel point embossing with interchangeable characters. Single row or multi row available.

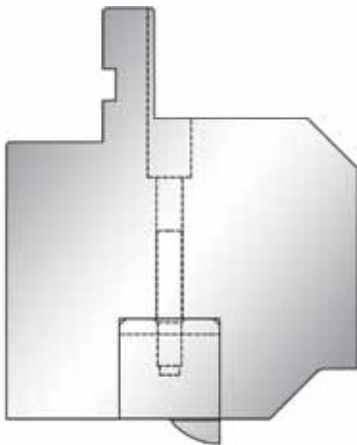

### LL1

Multiple louver configurations are available. For louver forming, sheet perforation is required.

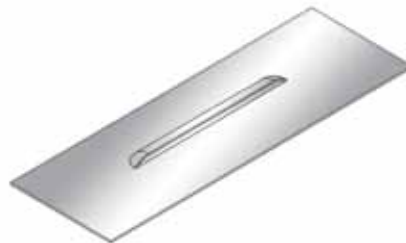
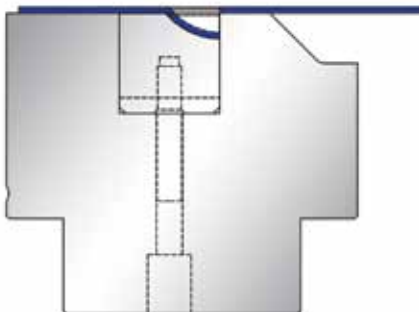

**CHANNEL**

These sets are recommended for applications where considerable spring back is encountered. Secondary flattening operations may be required.

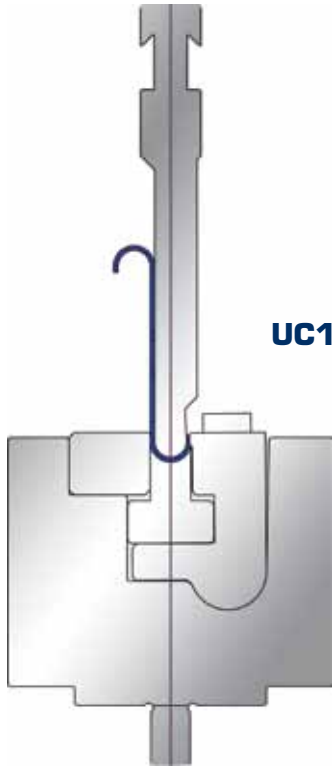
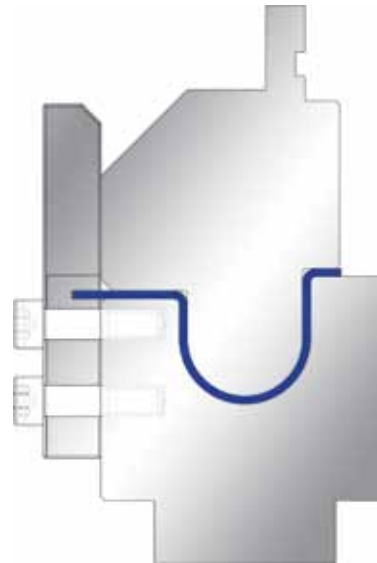
**UC1****UC2****UC3****HT1**

These sets provide straight wall or angled wall hat channel bending in one stroke.

Spring back allowance is built in.

## CHANNEL

These sets are required for deep channels when the channel bottom needs to remain flat.

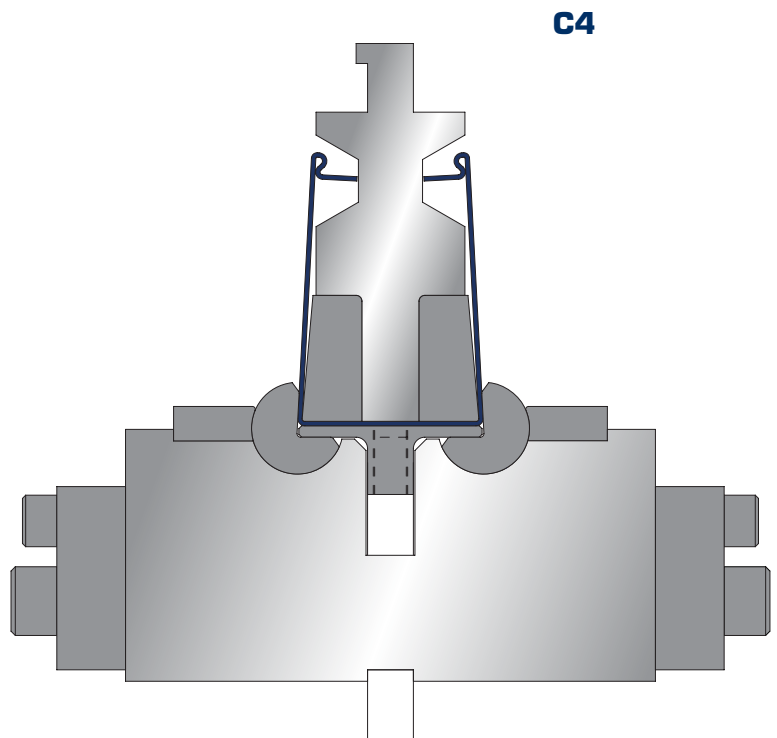
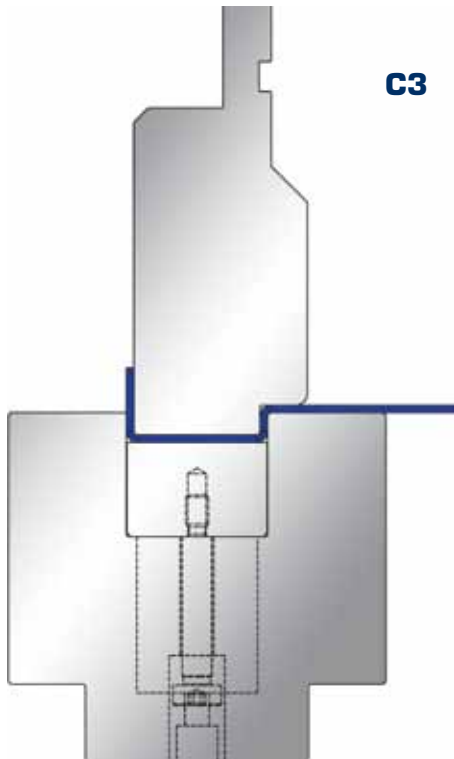
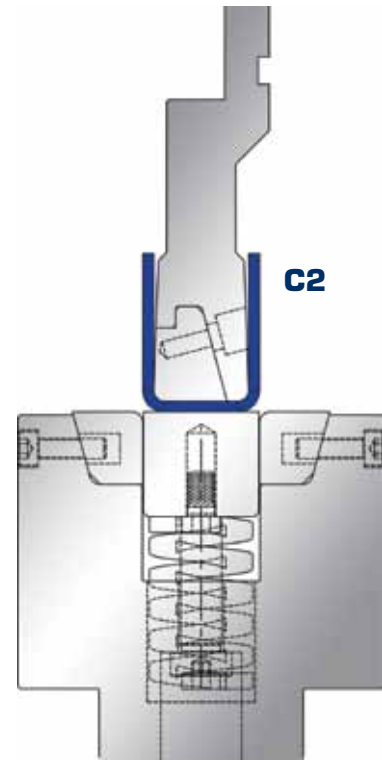
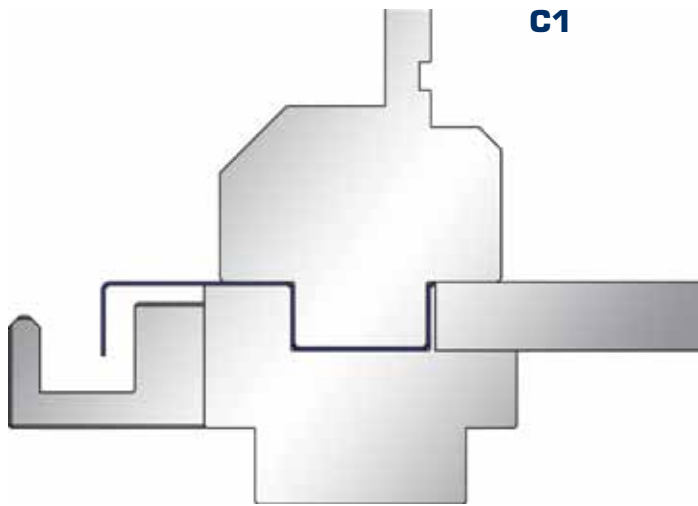

## CURL

MECHANICAL

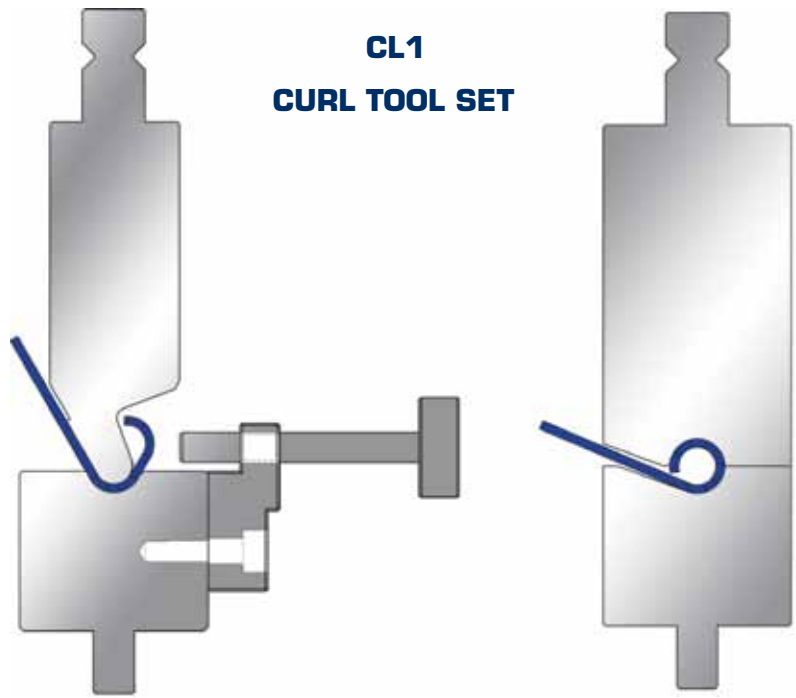

**CL2**

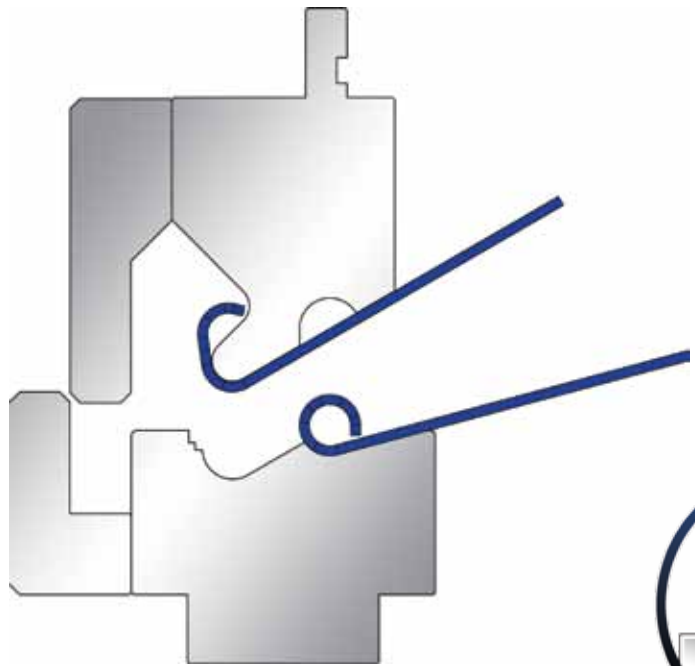

**Local**  
Tel: 651-286-6001  
Fax: 651-286-5959

**Toll Free U.S.A. & Canada**  
Tel: 800-445-4518  
Fax: 800-539-4590

**Toll Free Mexico**  
Tel: 001-800-741-2510  
Fax: 001-800-544-2096

**Website & Email**  
www.wilsonsontool.com  
pressbrake@wilsonsontool.com

## CURL

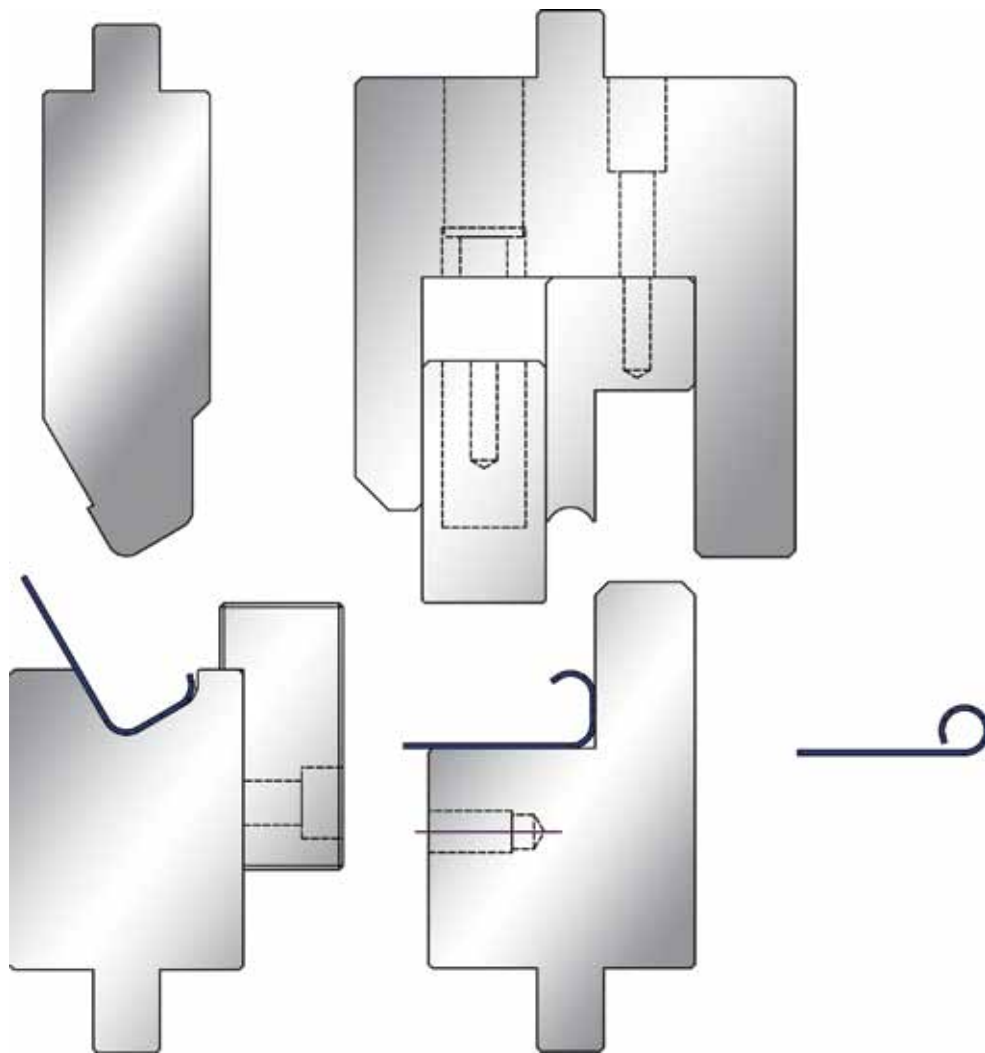

### CL3

These sets are used for hinges and corner beading.  
Call for specific application recommendations.

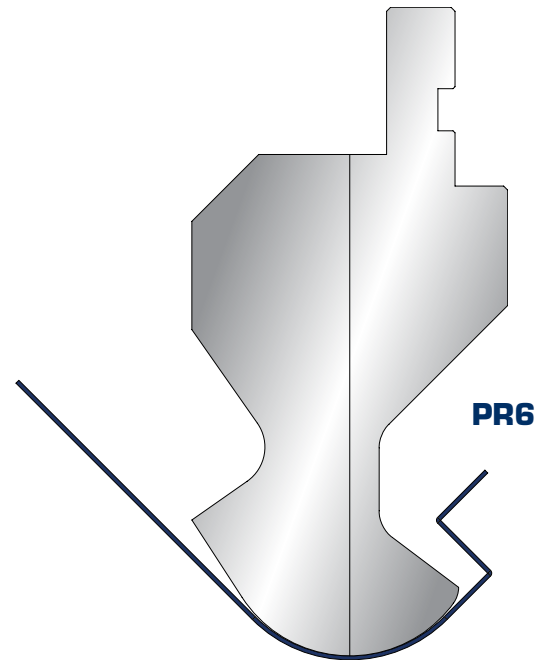
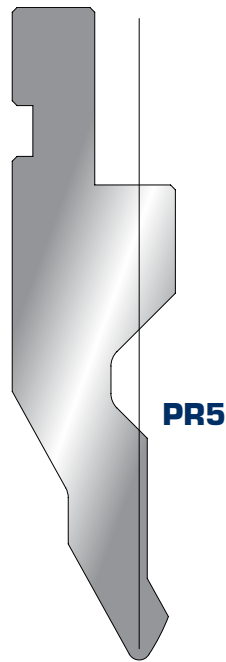
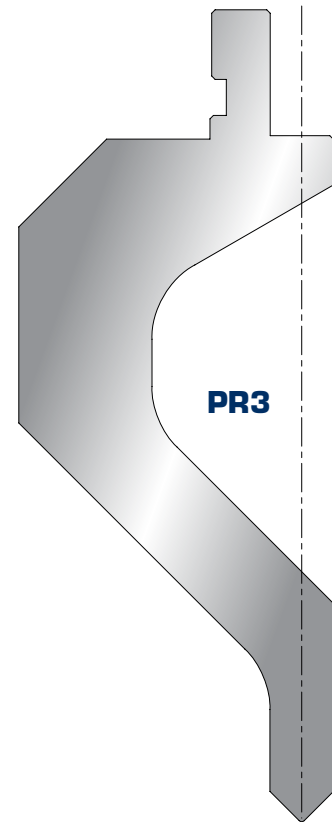
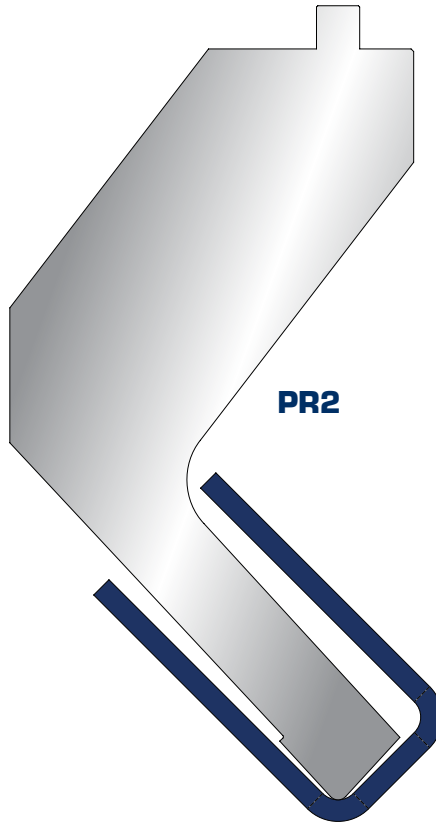
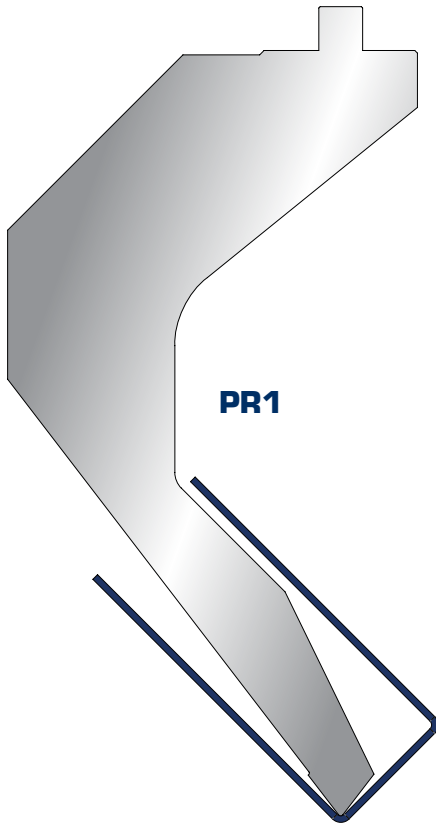

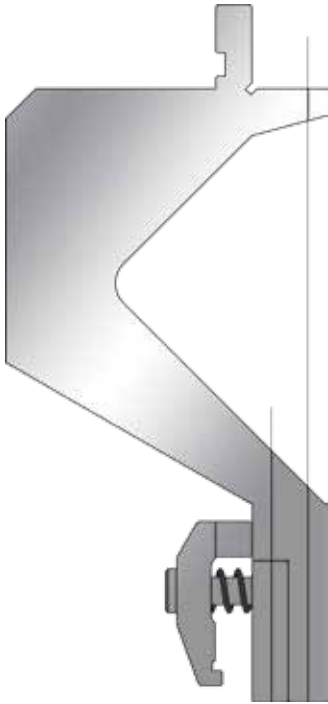

**43002**  
**Euro Z1 or Z2 Clamping**

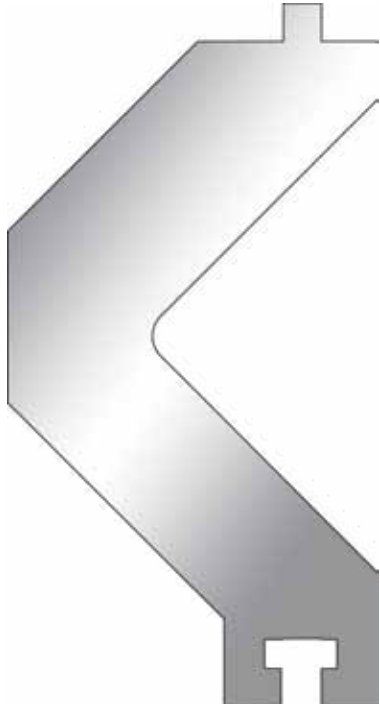

**AM Gooseneck Holder**

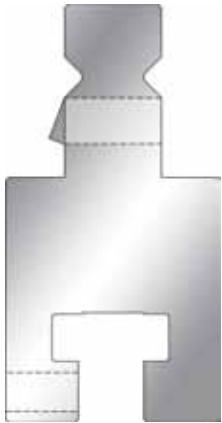

**WT - American**



**AM Self Seat**

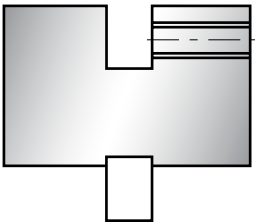

**Die Holder**



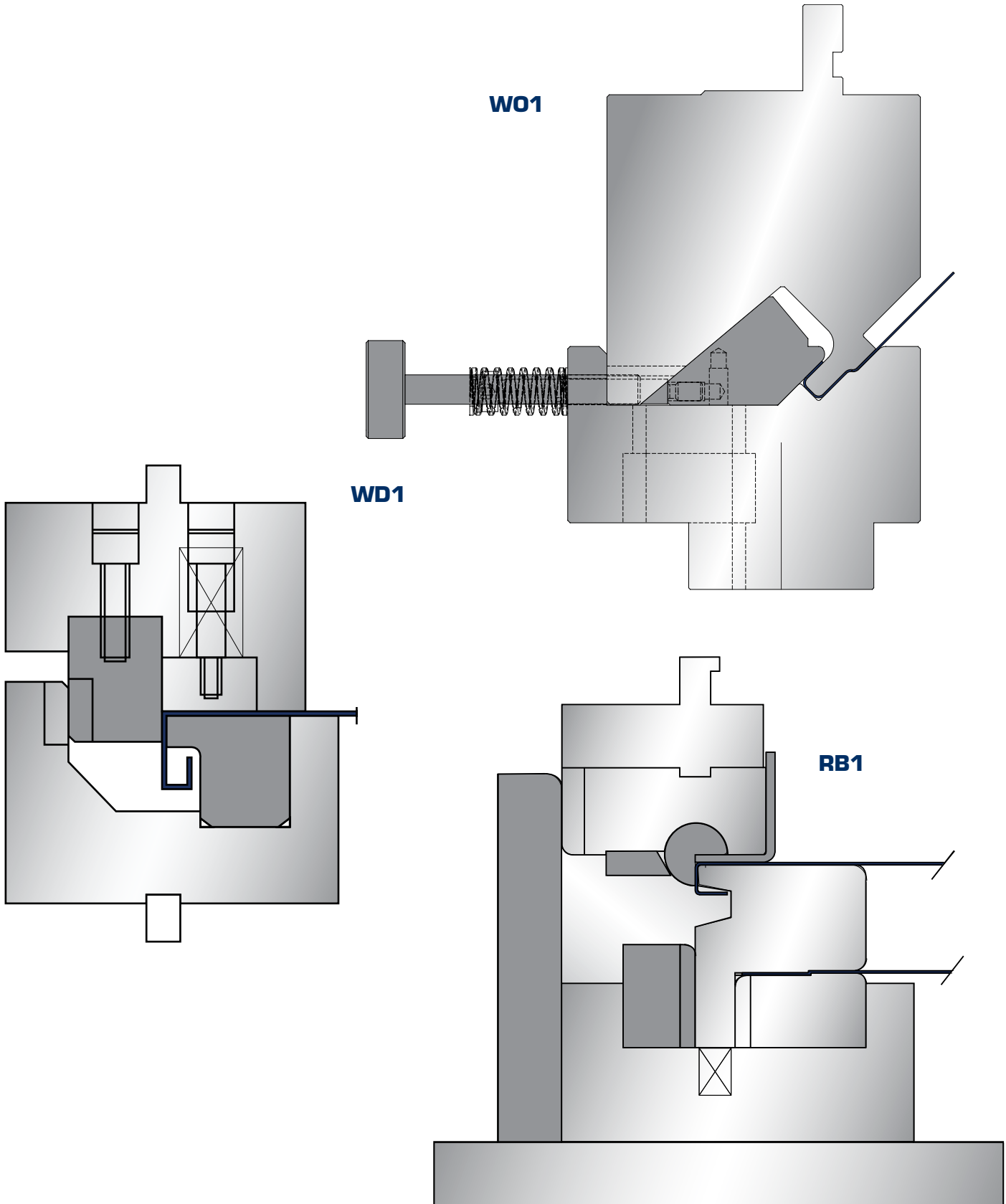









# WIPING AND ROTARY BENDING



## Press Brake Multiple Bend Allowances and Tonnage Estimates

Formula for making multiple bends on a press brake. For shape as shown, in mild steel with radii equal the metal thickness unless otherwise noted.

**Multiply Metal thickness By Factor = Tons Per Ft.**

SHAPE	DESCRIPTION	AIRFORM	BOTTOMING
	VEE DIE	60	150
	WIPING	---	250
	OFFSET	150	300/600
	MT'L THK OFFSET	300	600
	CHANNEL	225	300
	VEE RIB	200	600
	W DIE	300	600
	OPEN HAT CHANNEL	300	450
	SQ HAT CHANNEL	---	600
	PREFORM CURL	---	300
	PREFORM CURL	---	200
	CLOSE CURL	---	300
	RADIUS	---	180/300
Shape Considerations		Large Radii Angle Variation Concave or Convex Sides	Mat'l Thk. Radii Min. Angle Variation Maintain Flatness

Stainless Steel	(18-8 Annealed) Type 304 . . . . .	1.55
Aluminum	3303-H14 (1/2Hard) . . . . .	.35
	5052-H34 (1/2 Hard) . . . . .	.65
	6061-T64 . . . . .	.75
Brass	70/30 (1/2 Hard) . . . . .	1.10

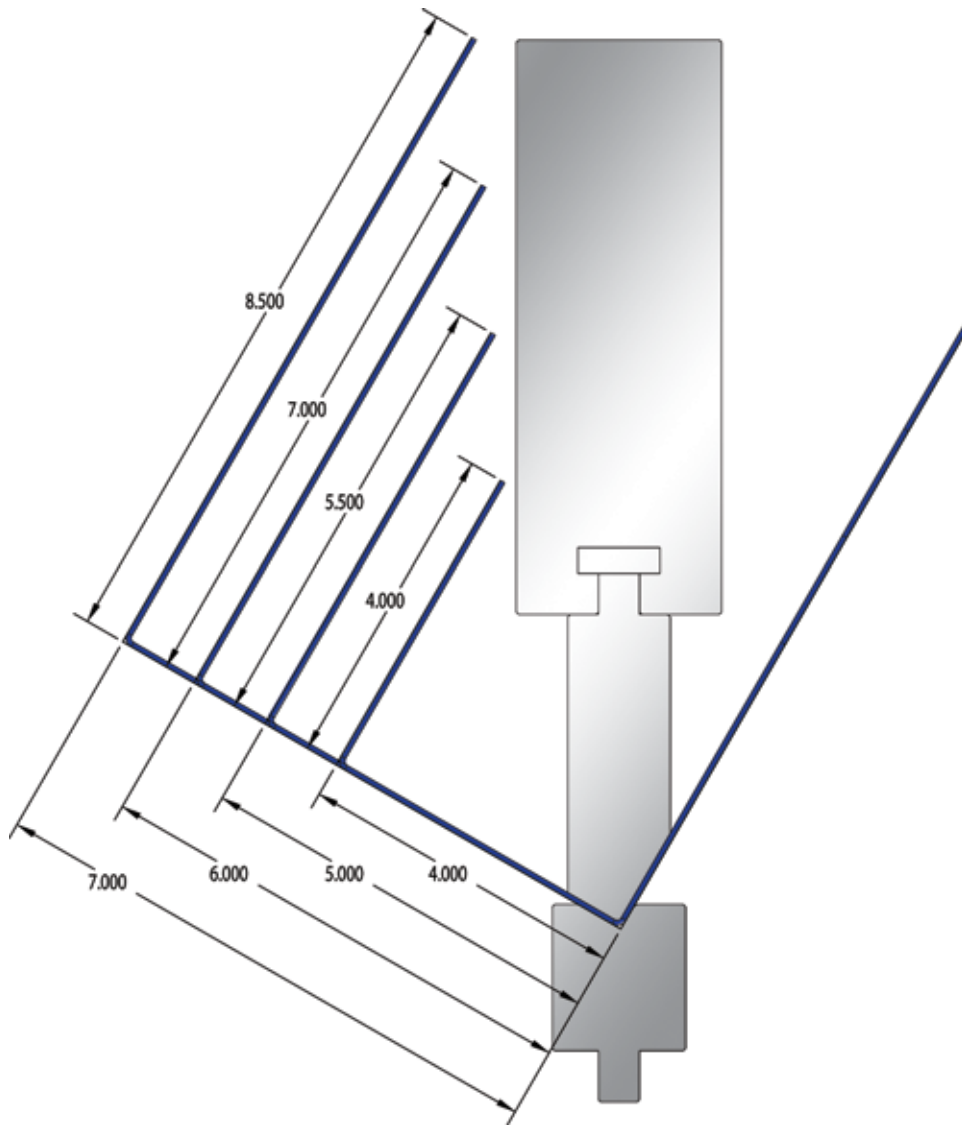
**30/60**

When forming a four-sided box, the punch must be sufficient height to prevent the pre-formed side from striking the upper beam.



## **ORDER**

Minimum order is \$50.00.

## **CREDIT REQUIREMENTS**

All orders are subject to approval by our Credit Department. If you are a new account, please furnish us with your tax exempt status, a bank reference, three current supplier references and/or your current D&B rating with your first order. A credit limit will be imposed on new accounts until credit has been established.

## **PAYMENT TERMS**

Terms are net 10 days. Catalog prices are subject to change without notice.

## **FREIGHT**

Orders are shipped F.O.B. from our manufacturing facility. (International Shipments are Incoterms: Ex Works).

## **ORDER CANCELLATION**

In the event an order is cancelled, an additional charge will be assessed to cover the cost of labor and material.

## **RETURNED MATERIAL**

A handling/restocking fee will be applied to all products returned for credit. A return authorization number and shipping instructions must be obtained in advance before an item can be returned.

## **CLAIMS**

All claims or product shortages must be made within 30 days of the invoice date.





## PRECISION TOOLING. UNBEATABLE PERFORMANCE.

For more than 40 years, Wilson Tool International® has provided industry-leading tooling solutions that enhance the performance of sheet metal fabricators and stampers worldwide.

The three divisions of Wilson Tool – Punching, Press Brake, and Stamping – represent the most comprehensive line of tooling systems and accessories available. Our ability to consistently provide innovative, high quality products that outlast and outperform the competition is why the world's most successful fabricators rely upon Wilson Tool tooling systems.

A knowledgeable global sales force, multilingual customer support staff, same-day shipping and extensive distribution network are just a few of the benefits that keep our customers coming back time and again.



Press Brake Division  
12912 Farnham Avenue • White Bear Lake, MN 55110

Tel (Free): 800-445-4518  
Fax (Free): 800-539-4590  
Email: [pressbrake@wilsontool.com](mailto:pressbrake@wilsontool.com)  
[www.wilsontool.com](http://www.wilsontool.com)

## WILSON TOOL INTERNATIONAL

### Wilson Tool International, Inc. - United States

Tel (Free): 800-328-9646 | Tel: 651-286-6001  
Fax (Free): 800-222-0002 | Fax: 651-286-5959  
Email: [sales@wilsontool.com](mailto:sales@wilsontool.com)

### Wilson Tool International, Ltd. - United Kingdom

Tel (Free): 0800-373748 | Tel: +44 1793 831818  
Fax (Free): 0800-373758 | Fax: +44 1793 831945 or 46  
Email: [sales@wilsontool.eu.com](mailto:sales@wilsontool.eu.com)

### Wilson Tool International - China

Tel: +86 21 51089638 | Fax: +86 21 64422195  
Email: [sales@wilsontool.cn](mailto:sales@wilsontool.cn)

### Wilson Tool International - Germany

Tel (Free): 00800-9457668665 | Tel: +49 5723 747 0  
Fax (Free): 00800-945766329 | Fax: +49 5723 747 10  
Email: [verkauf@wilsontool.eu.com](mailto:verkauf@wilsontool.eu.com)

### Wilson Tool International A/S - Denmark

Tel (Free): 80 20 20 24 | Tel: +45 44 53 1699  
Fax (Free): 80 20 20 26 | Fax: +45 44 53 0607  
Email: [sales@wilsontool.dk](mailto:sales@wilsontool.dk)

### Wilson Tool International - France

Tel: +33 (0) 164 13 47 80 | Fax: +33 (0) 164 13 47 81  
Email: [ventes@wilsontool.eu.com](mailto:ventes@wilsontool.eu.com)

### Wilson Tool International - Argentina

Tel: +54 114 7634004 | Fax: +54 114 5084190  
Email: [ventasargentina@wilsontool.com](mailto:ventasargentina@wilsontool.com)

### Wilson Tool - South Africa (Pty) Limited

Tel: +27 877 217 875 | Fax: 086 657 8629  
Email: [simon.penny@wilsontool.com](mailto:simon.penny@wilsontool.com)

### The Wilson Tool Company S. de R.L. de C.V. - Mexico

Tel: 52 (81) 8865-4820 | Fax: 52 (81) 8865-4599  
Email: [ameralatina@wilsontool.com](mailto:ameralatina@wilsontool.com)

### Exacta Precision Products - Ontario

Tel: 800-268-5573 | Fax: 800-668-9314  
Email: [info@exactapunch.com](mailto:info@exactapunch.com)

### Exacta FabTool - Ontario

Tel: 905-840-2240 | Fax: 905-840-1032  
Email: [info@exactafabtool.com](mailto:info@exactafabtool.com)